

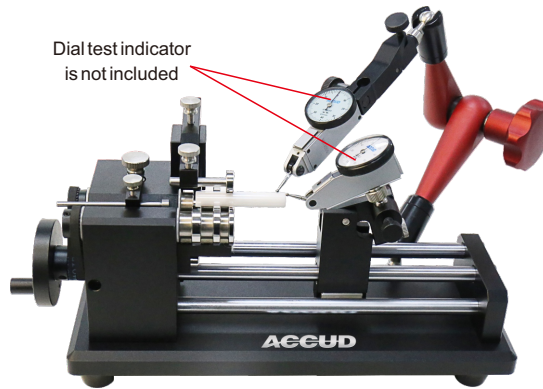

SERIES 661

**QUICK POSITIONING
CONCENTRICITY GAUGE**

- ◆ Quick positioning, suitable for mass measurement
- ◆ Optional accessories: dial test indicator (code: 261-002-01 or 261-002-02)



661-002-01

unit: mm

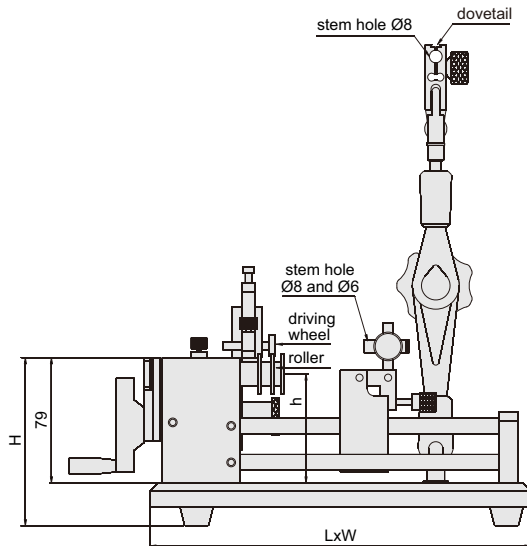

661-002-01

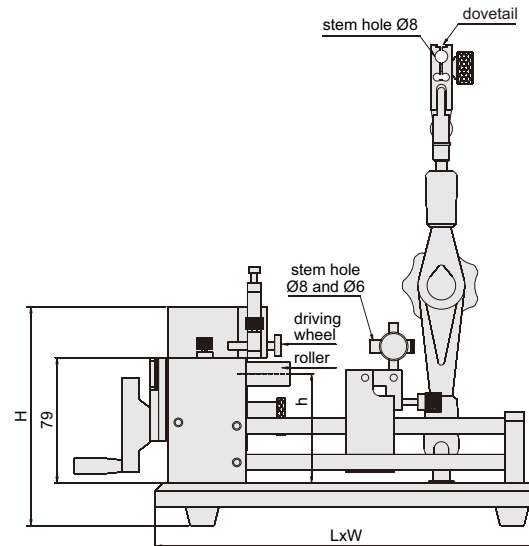

661-004-01

Code	Diameter range	Workpiece length	Accuracy	Center height (h)	LxWxH
661-002-01	Ø1-35mm	15-100mm	2µm	70mm	260x100x130
661-004-01	Ø20-110mm	15-200mm	2µm	70mm	340x150x145

* **NEW**