

## SERIES 662

## BENCH CENTER

Dial test indicator  
is not included

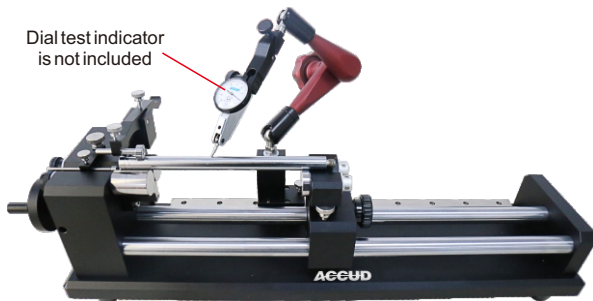

662-300-11

- ◆ Double guide
- ◆ Quick positioning, suitable for mass measurement
- ◆ Supplied with standard rod to verify accuracy
- ◆ Optional accessories: dial test indicator  
(code: 261-002-01 or 261-002-02)

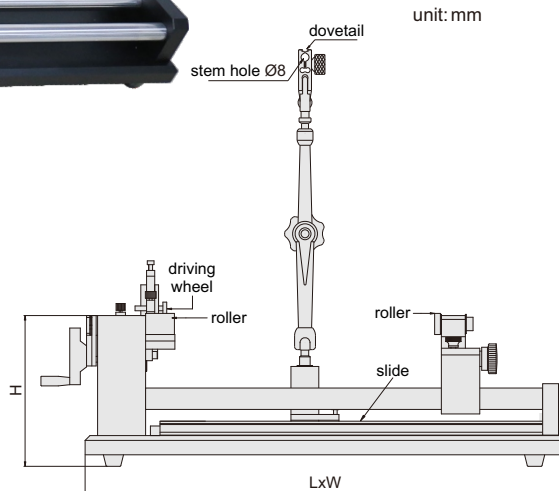

unit: mm

Code	Applicable diameter	Workpiece length	Accuracy	LxWxH
662-300-11	Ø3-40mm	300mm	2µm	500x130x135
662-600-11	Ø3-40mm	600mm	2µm	760x120x150