

SERIES 907

PRECISION STRAIGHT EDGE WITH BEVELED EDGE



907-012-11

unit: mm

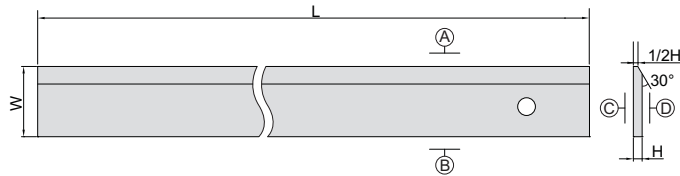

Application

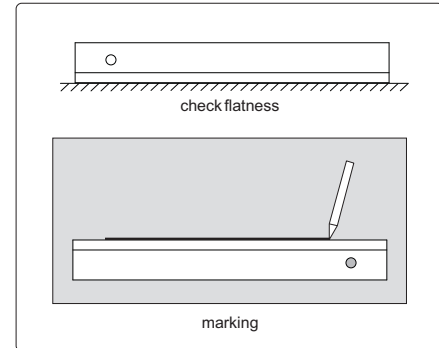

- ◆ Check flatness and for marking
- ◆ Made of tool steel

Code	Range(L)	Flatness of A and B	Flatness of C and D	W	H
907-012-11	305	0.005	0.05	41	6.3
907-024-11	610	0.006	0.06	51	7.9
907-036-11	914	0.007	0.06	64	9.5