

689

# NON-MAGNETIC EDGE FINDER

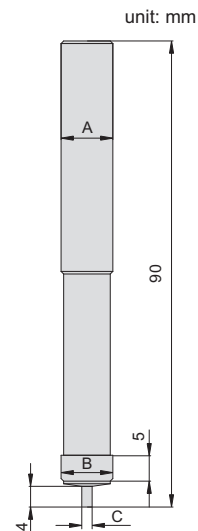

- ◆ Non-magnetic
- ◆ TIN coating, hardness HV2300, extremely wear resistance
- ◆ Suitable for machine speed 400~600rpm

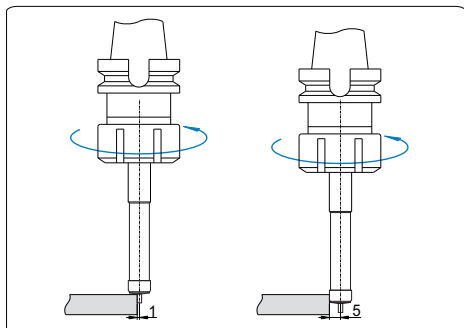

Code	Shank(A)	Contact point(B)	Contact point(C)	Accuracy
689-010-02	Ø10mm	Ø10mm	Ø2mm	5µm