

SERIES 692

ELECTRONIC EDGE FINDER

- ◆ The LED will be light with alarm when the ball contacts the workpiece
- ◆ Not suitable for rotating use
- ◆ Hardened shank and contact point
- ◆ Battery:23A, 12V

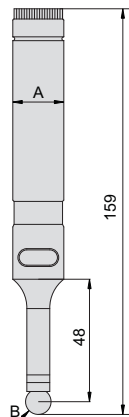
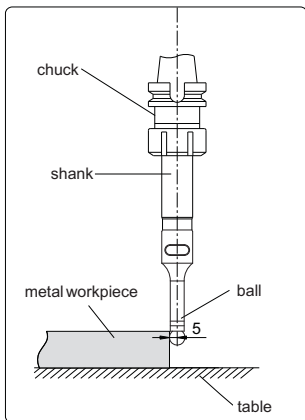

692-010-03N

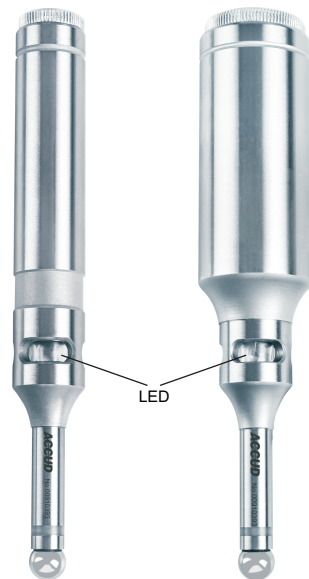

692-010-32

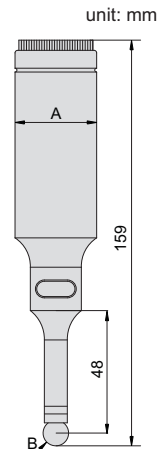

Code	Shank(A)	Contact point (B)	Accuracy
692-010-03N	Ø20mm	SØ10mm	5µm
692-010-32	Ø32mm	SØ10mm	5µm