

694

EDGE FINDER

- ◆ Hardened shank and contact point
- ◆ Suitable for machine speed 400~600rpm

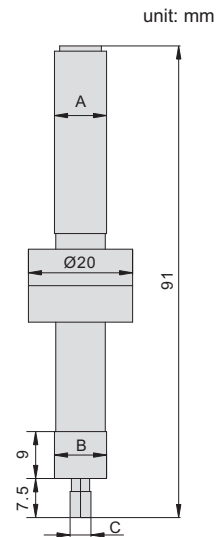
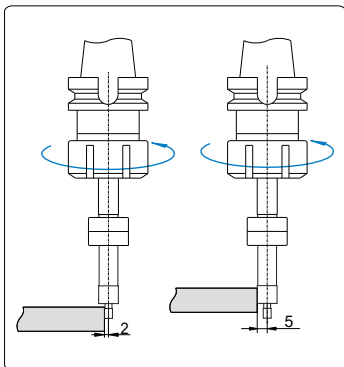

Code	Shank(A)	Contact point(B)	Contact point(C)	Accuracy
694-020-01N	Ø10mm	Ø10mm	Ø4mm	5µm