

SERIES 636

V-BLOCK SET

- ◆ Hold cylindrical workpieces for inspection and machining
- ◆ Two V-blocks per set
- ◆ V groove on the top for large shafts
- ◆ V groove on the bottom for small shafts



636-045-01

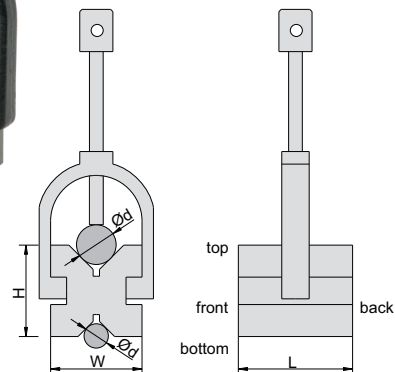
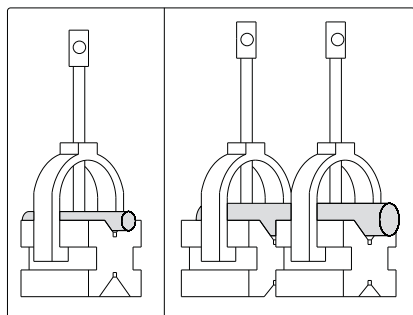

Code	Size(LxWxH)	For shaft range(Ød)	V grooves to top and bottom sides parallelism	V grooves to front and back sides squareness	Height difference of a matched pair
636-045-01	45x41x35mm	5-40mm	5µm	5µm	5µm
636-070-01	70x63x44mm	7-60mm	5µm	5µm	5µm
636-125-01	125x90x70mm	7-90mm	5µm	5µm	5µm

