

- ◆ Adjustable scale to compensate pointer wear
- ◆ Made of stainless steel

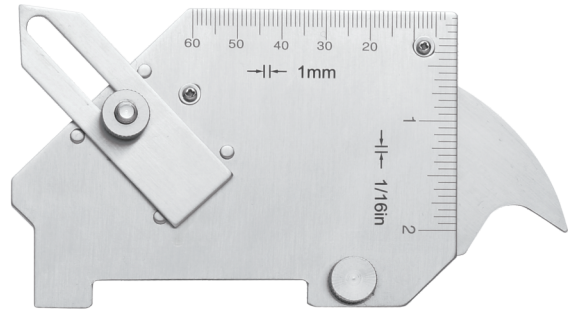

front side



reverse side

measure crown height	measure fillet weld leg height	measure misalignment	measure undercut depth
measure fillet weld throat size	measure angle of preparation	measure length	measure 45° angle

SIMPLE MEASURING TOOL

Code	Application	Range	Graduation	Accuracy
975-025-01	measure crown height	0 - 25mm (0 - 1")	1mm (1/16")	±0.5mm
	measure fillet weld leg height	0 - 25mm (0 - 1")	1mm (1/16")	±0.5mm
	measure misalignment	0 - 25mm (0 - 1")	1mm (1/16")	±0.5mm
	measure undercut depth	0 - 2mm (0 - 1/8")	1mm (1/16")	±0.5mm
	measure fillet weld throat size	0 - 20mm (0 - 3/4")	1mm (1/16")	±0.5mm
	measure angle of preparation	0 - 60°	5°	±1°
	measure length	0 - 60mm (0-2")	1mm (1/16")	±0.5mm
	measure 45° angle	—	—	±1°

