

- ◆ Graduation: 0.01mm
- ◆ Indicator travel: 30mm
- ◆ Accuracy: $\pm 0.03\text{mm}$
- ◆ Stainless steel base
- ◆ With needle and ball styli
- ◆ Extension rod: 25mm (1pc), 50mm (1pc), 75mm (1pc), 100mm (2pcs)

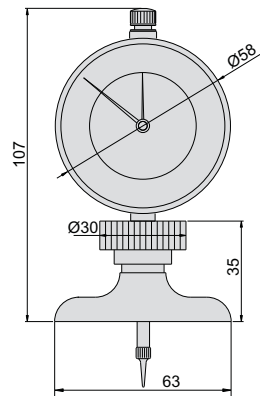

292-300-11

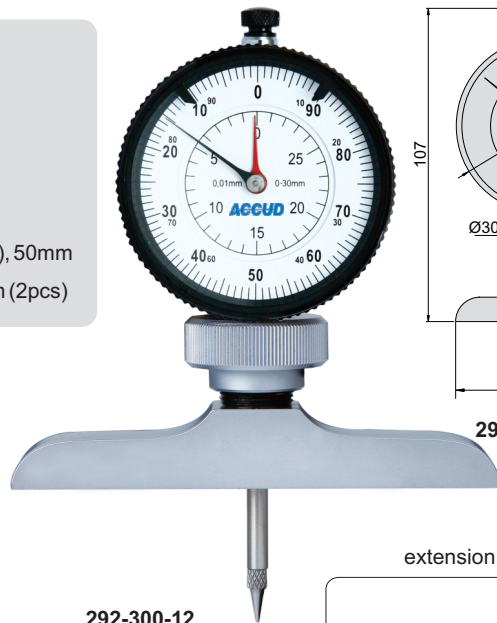
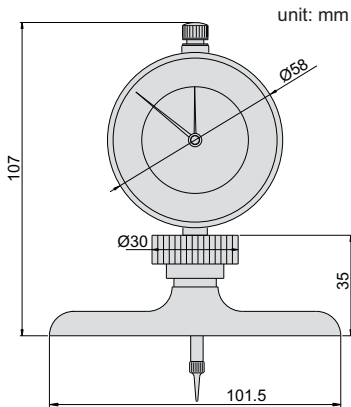

292-300-12

unit: mm

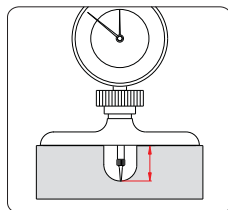

292-300-12

Code	Range	Base
292-300-11	0-300mm	63x17mm
292-300-12	0-300mm	101.5x17mm

extension rods

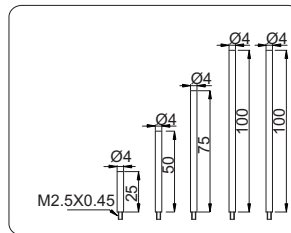

styli (included)

