

Takım Kodu
Ordering Code
Bestell-Bezeichnung

Stok Stock Lager	Takım Ölçüleri (mm) Dimension (mm) Abmessung (mm)					Kesici Uç Insert Wendeschneidplatte	Yedek Parçaları / Spare Parts / Ersatzteile			
	DC	ZEPF	DCON	LF	APMX		Sıkma Vidası Screw Schraube	Tork Anahtar Torx Key Torx-Schlüssel	Montaj Vidası Mounting Screw Befestigungsschraube	
• new	AFM90-L00904-D040-A16-Z06-H	40	6	16	40	8	LOGU 0904..	3007-M2.7x8	82-T07	2506-M8x30
• new	AFM90-L00904-D050-A22-Z05-H	50	5	22	40	8				2508-M10x30
• new	AFM90-L00904-D050-A22-Z07-H	50	7	22	40	8				2506-M8x30
• new	AFM90-L00904-D063-A22-Z06-H	63	6	22	40	8				2508-M10x30
	AFM90-L01207-D040-A16-Z04-H	40	4	16	40	11	LOGU 1207..	3015-M4x11	80-T15	2506-M8x30
	AFM90-L01207-D050-A22-Z05-H	50	5	22	40	11				2508-M10x30
	AFM90-L01207-D063-A22-Z05-H	63	5	22	40	11				2510-M12x35
• new	AFM90-L01207-D063-A22-Z06-H	63	6	22	40	11				2514-M16x35
• new	AFM90-L01207-D080-A27-Z07-H	80	7	27	50	11				
• new	AFM90-L01207-D100-A32-Z07-H	100	7	32	50	11				

MTSBH Ucuna Uygundur. / Compatible with MTSBH Insert. / Kompatibel mit MTSBH Wendeplatten.

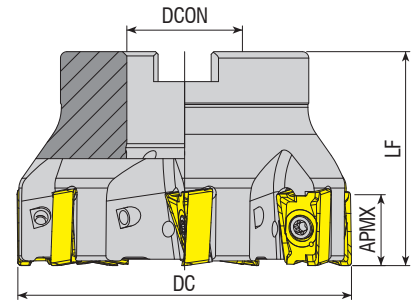

Takım Kodu
Ordering Code
Bestell-Bezeichnung

Stok Stock Lager	Takım Ölçüleri (mm) Dimension (mm) Abmessung (mm)					Kesici Uç Insert Wendeschneidplatte	Yedek Parçaları / Spare Parts / Ersatzteile			
	DC	ZEPF	DCON	LF	APMX		Sıkma Vidası Screw Schraube	Tork Anahtar Torx Key Torx-Schlüssel	Montaj Vidası Mounting Screw Befestigungsschraube	
	AFM90-LN15T6-D050-A22-Z05-H	50	5	22	40	15.5	LNGU 15T6..	4015-M4x12	80-T15	2508-M10x30
	AFM90-LN15T6-D063-A22-Z06-H	63	6	22	40	15.5				2510-M12x35
	AFM90-LN15T6-D080-A27-Z07-H	80	7	27	50	15.5				

R: Sağ / Right / Rechts L: Sol / Left / Links
• Stokta / In Stock / Auf Lager ◦ Stokta Yok / Non Stock Item / Kein Lagerartikel, Lieferzeit auf Anfrage
KNMTL Ucuna Uygundur. / Compatible with KNMTL Insert. / Kompatibel mit KNMTL Wendeplatten.

Sipariş Örneği/Ordering Example/Bestellbeispiel
1 ad./pcs./stück AFM90-L009-D040-A16-Z06-H
Kesme Hesabı : S 377 / Cutting Calculation : P 377 / Schnittberechnung : P 377
Montaj Ölçüleri : S 374 / Mounting Reference : P 374 / Montagehinweis : P374