

EINSTECHEN (außen und innen)

GROOVING (external and internal)



WENDESCHNEIDPLATTE Typ

INDEXABLE INSERT Type

312

mit runder Spanleitstufe
with round chip breaker

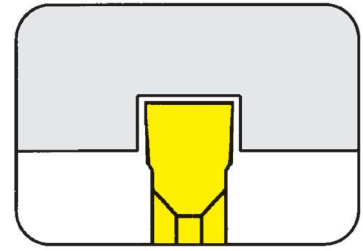

Seegerringnuten
Nutnennbreite Nw

Circlip grooves
Width of circlip Nw

DIN 471/472
0,50 - 5,15 mm

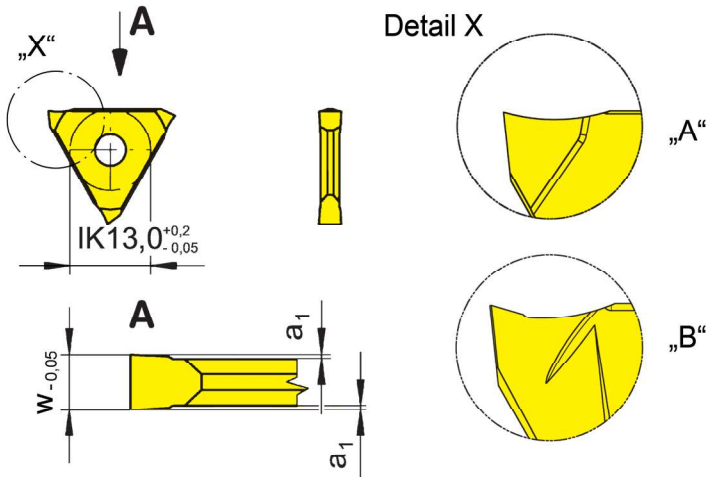

Form A = komplett geschliffen
Form A = completely ground

Form B = teilgeschliffen
Form B = partially ground

für Klemmhalter
for use with Toolholder

Typ 309
Type 330
360
361
369
390

Wechselgenauigkeit
Länge $\pm 0,02$ mm
Indexability length $\pm 0,02$ mm

Bestellnummer Part number	Nw	w	a ₁	Form Form	Größe Size	K10	MG12	P20	H20	TN32	TN35	TI25	TF45	TF46
312.0050.00	0,50	0,57	0,07			▲		▲		▲			▲	▲
312.0060.00	0,60	0,67	0,07			▲		▲		▲			▲	▲
312.0070.00	0,70	0,77	0,08			▲		▲		▲			▲	▲
312.0080.00	0,80	0,87	0,08			▲		▲		▲			▲	▲
312.0090.00	0,90	0,97	0,08	A	01	▲		▲		▲	▲		▲	▲
312.0100.00	1,00	1,07	0,09			▲		▲		▲			▲	▲
312.0110.00	1,10	1,24	0,20			▲		▲		▲			▲	▲
312.0130.00	1,30	1,44	0,20			▲		▲		▲			▲	▲
312.0160.00	1,60	1,74	0,20			▲		▲		▲			▲	▲
312.0185.00	1,85	1,99	0,20	B	01	▲	▲	▲	▲	▲	▲	▲	▲	▲
312.0215.00	2,15	2,29	0,20			▲	▲	▲	▲	▲	▲		▲	▲
312.0265.00	2,65	2,79	0,20	B	02	▲	▲	▲	▲	▲	▲		▲	▲
312.0315.00	3,15	3,29	0,20	B	03	▲		▲	▲	▲	▲		▲	▲
312.0415.00	4,15	4,29	0,20			▲		▲		▲	▲		▲	▲
312.0515.00	5,15	5,29	0,20	B	04	▲		▲	▲	▲	▲		▲	▲
						P	●	○	●	●	●	●	●	●
						M	○	●	○	●	●	●	●	○
						K	●	●	●	●	●	●	●	●
						N	●	●	●	●	●	●	●	●
						S	○	●	●	●	●	●	●	○
						H								

- ▲ ab Lager / on stock Δ 4 Wochen / 4 weeks
- Haupteinsatzbereich / main recommendation
- bedingt einsetzbar / alternative recommendation
- unbeschichtete HM-Sorten / uncoated grades
- beschichtete HM-Sorten / coated grades
- bestückt/Cermet / brazed/Cermet

Abmessungen in mm
Dimensions in mm

Wendeschnidplatten sind in **rechten und linken** Klemmhaltern verwendbar.
Indexable inserts can be used in **right and left hand** toolholders.

HM-Sorten
Carbide grades

